

Magnetic float switch For horizontal installation Model HLS

WIKA data sheet LM 30.02



Applications

- Level measurement for almost all liquid media
- Pump and level control
- Chemical, petrochemical, natural gas, offshore, shipbuilding, machine building, power generating equipment, power plants
- Process and drinking water treatment

Special features

- Large range of application due to the simple, proven functional principle
- For harsh operating conditions, long service life
- Operating limits:
 - Operating temperature: $T = -196 \dots +350 \text{ }^{\circ}\text{C}$
 - Operating pressure: $P = \text{vacuum to } 232 \text{ bar}$
 - Limit density: $\rho \geq 600 \text{ kg/m}^3$
- Stainless steel and plastic versions
- Explosion-protected versions

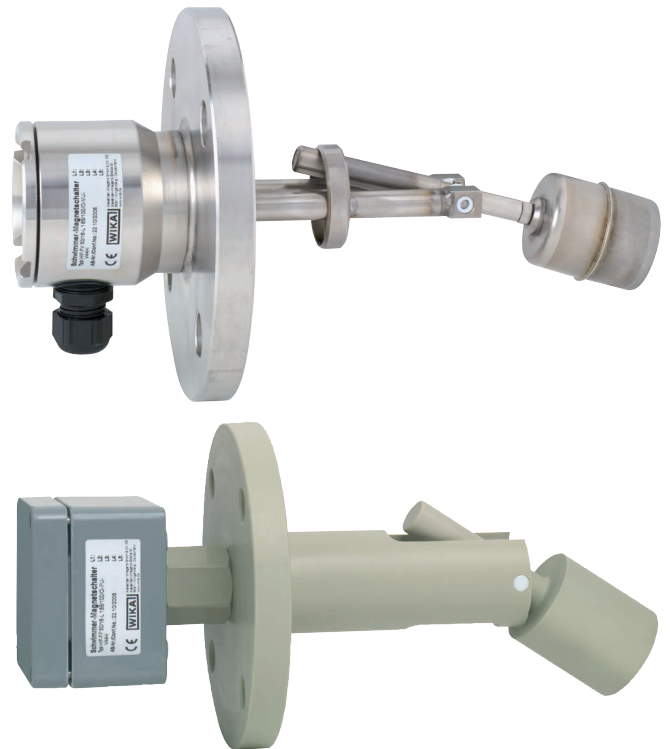

Fig. top: Stainless steel version, model HLS-S
Fig. bottom: Plastic version, model HLS-P

Description

In addition to the various applications for float switches for vertical installation (model FLS), the model HLS horizontal float switches likewise offer innumerable possibilities to monitor and/or switch levels in order to indicate minimum/maximum levels.

The float is attached to a supported, swivelling lever and moves with the level of the medium being measured. By means of a permanent magnet, fixed to the end of the lever, when a preset switch point is reached, a reed contact (inert gas contact) within the contact pipe is actuated.

By using a permanent magnet and a reed contact the switching operation is non-contact, free from wear and needs no power supply. The functioning of the float switch is independent of foaming, conductivity, vapours, bubble formation and vibrations.

The signal processing is universal. Direct connection to PLCs, NAMUR connections, signal amplifiers or contact protection relays is possible.

The float switch is simple to mount and maintenance-free, so the costs of mounting, commissioning and operation are low.

Model overview

Float switch model	Description	Approval					
		without	Ex i	Ex d	GL	ABS	Ex i + GL
HLS-S	Magnetic float switch, standard version	x	x	x	x	x	x
HLS-P	Magnetic float switch, plastic version	x					

Float switch model	Materials			Temperature range	Max. pressure
	Stainless steel 1.4571 (316Ti)	Stainless steel 1.4404 (316L)	Polypropylene		
HLS-S	x	x		-196 ... +350 °C	232 bar
HLS-P			x	-10 ... +80 °C	6 bar

Ex approvals

Explosion protection	Ignition protection type	Model	Zone	Approval number
ATEX	Ex i	HLS-S-Ex i	Zone 0, gas Zone 1, gas/dust	IBExU 03 ATEX1038X II 1G/2GD EEx ia IIC T2 ... T6
	Ex d	HLS-S-Ex d	Zone 1, gas	TÜV 09 ATEX 7632X II 2G Ex d IIC T6, II 2D Ex tD A21 IP 65 T80 °C
	Ex i + GL	HLS-S-Ex i	Zone 0, gas Zone 1, gas/dust	IBExU03ATEX1038X II 1G/2GD EEx ia IIC T6-T2 + GL-32527 - 06 HH

Type approval

Approval	Model	Approval number
GL	HLS-S	GL - 32 527 - 06 HH
ABS	HLS-S	ABS-02-HG286248-2-PDA
GOST	HLS-S, HLS-P	959333

Magnetic float switch, standard version, model HLS-S

Process connection, contact tube and float from stainless steel 1.4571

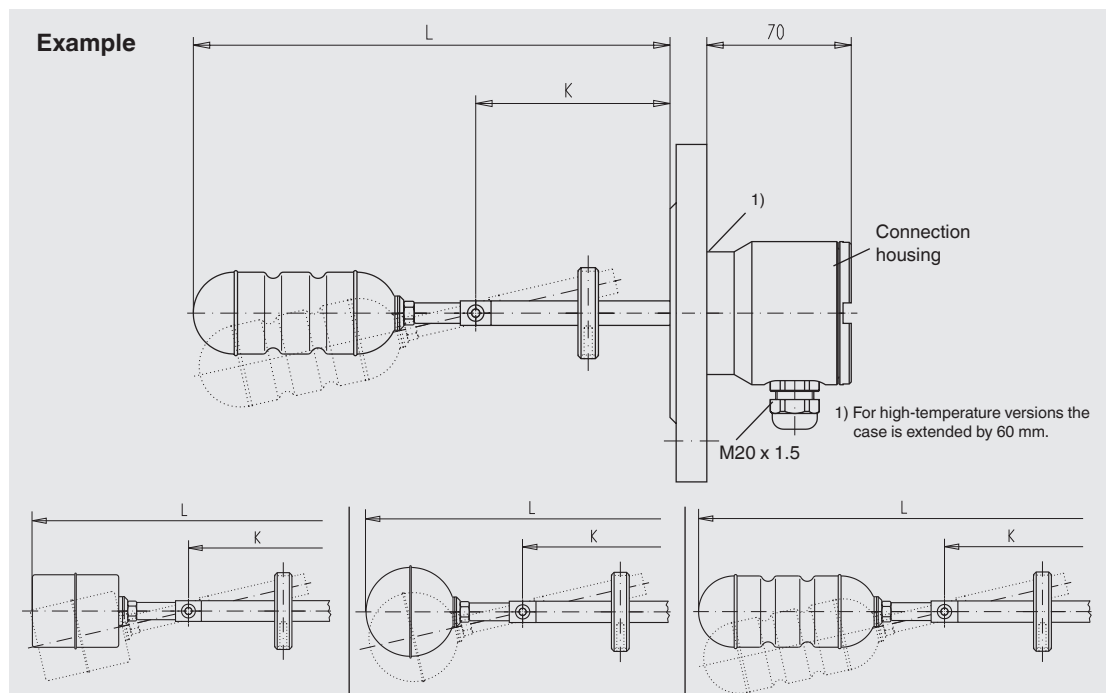

	Float model V44HI	Float model T52HI and T52HI/Gr. 5	Float model ZVSS43/100HI
Electrical connection	Connection housing	■ Stainless steel 1.4571	
Process connection	Mounting flange	■ DIN DN 50 ... DN 100, PN 6 ... PN 400 ■ EN 1092 DN 50 ... DN 100, PN 6 ... PN 400 ■ ANSI 2" ... 4", class 150 ... 600 ■ Square flange DN 80 and DN 92 (other flanges on request)	
Contact tube			
Insertion length L	193 ... 990 mm	185 ... 990 mm	240 ... 990 mm
Contact tube length K	100 ... 900 mm	100 ... 900 mm	100 ... 900 mm
Float material	Stainless steel 1.4571	Model T52HI: Titanium 3.7035, grade 2 Model T52HI/Gr. 5: Titanium 3.7165, grade 5	Stainless steel 1.4571
Float			
Diameter	44 mm	52 mm	43 mm
Length	52 mm	52 mm	100 mm
Max. operating pressure	6 bar	Model T52HI: 100 bar Model T52HI/Gr. 5: 232 bar	20 bar
Min. density	600 kg/m ³		
Temperature range			
Standard	-40 ... +250 °C		
Option: ■ High-temperature version:	-20 ... +350 °C		
Option: ■ Low-temperature version:	-196 ... +250 °C		
Switching function	selectable: 1 x change-over SPDT 1 x normally open NO - on rising level 1 x normally closed NC - on rising level 1 x proximity switch I - on rising or falling level		
Switching power	AC 230 V; 40 VA; 1 A	DC 230 V; 20 W; 0,5 A	Please observe contact protection measures!
	Attention: Versions without protective conductor connection - operation only at safety extra-low voltage e.g. contact protection relay or external grounding		
Mounting position	Horizontal ±30°		
Ingress protection	IP 67 per EN 60529 / IEC 60529		

Versions in titanium, Hastelloy or other materials on request

Magnetic float switch, intrinsically safe, model HLS-S-Ex i

IBExU 03 ATEX1038X II 1G/2GD EEx ia IIC T2 ... T6

Process connection, contact tube and float from stainless steel 1.4571

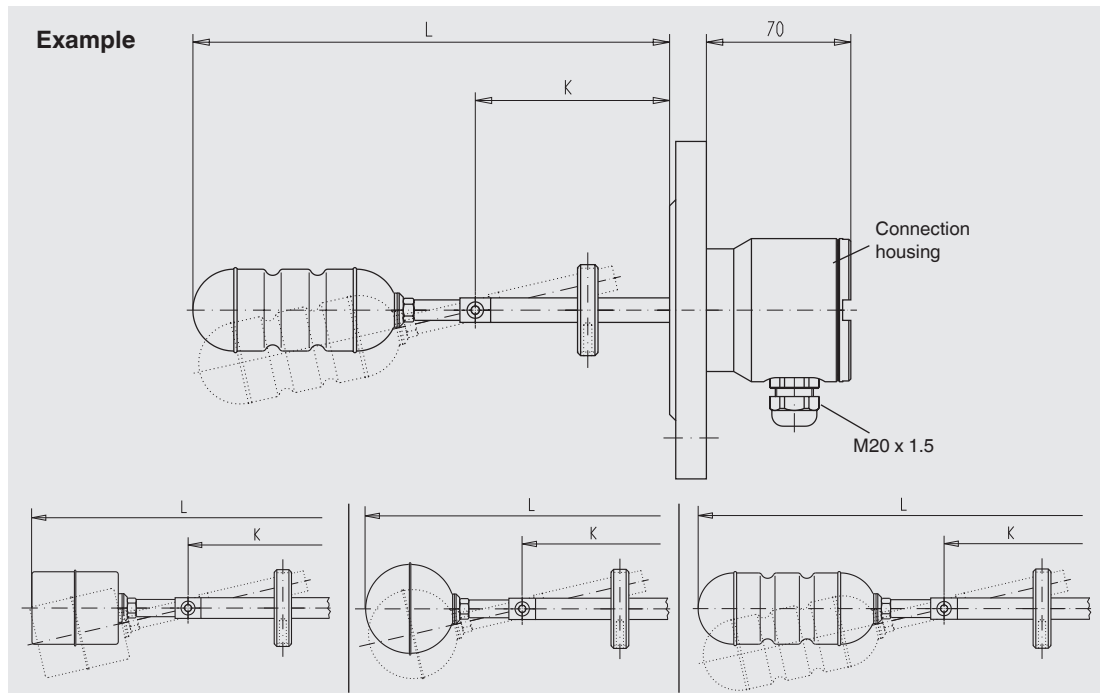

	Float model V44HI	Float model T52HI and T52HI/Gr. 5	Float model ZVSS43/100HI		
Electrical connection	Connection housing ■ Stainless steel 1.4571				
Process connection	Mounting flange ■ DIN DN 50 ... DN 100, PN 6 ... PN 160 ■ EN 1092 DN 50 ... DN 100, PN 6 ... PN 160 ■ ANSI 2" ... 4", class 150 ... 900 ■ Square flange DN 80 and DN 92 (other flanges on request)				
Contact tube Insertion length L Contact tube length K	193 ... 990 mm 100 ... 900 mm	185 ... 990 mm 100 ... 900 mm	240 ... 990 mm 100 ... 900 mm		
Float material	Stainless steel 1.4571	Model T52HI: Titanium 3.7035, grade 2 Model T52HI/Gr. 5: Titanium 3.7165, grade 5	Stainless steel 1.4571		
Float Diameter Length	44 mm 52 mm	52 mm 52 mm	43 mm 100 mm		
Max. operating pressure	6 bar	Model T52HI: 100 bar Model T52HI/Gr. 5: 180 bar	20 bar		
Min. density	600 kg/m ³				
Temperature class	T2	T3	T4	T5	T6
Process temperature	Max. 180 °C	160 °C	108 °C	80 °C	65 °C
Ambient temperature at case	Max. 80 °C	80 °C	80 °C	80 °C	60 °C
Switching function	1 x change-over SPDT				
Switching power	Only for connection to a certified intrinsically safe circuit with U _{max} 36 V, I _{max} 100 mA				
Mounting position	Horizontal ±30°				
Ingress protection	IP 67 per EN 60529 / IEC 60529				

Magnetic float switch, flameproof enclosure, model HLS-S-Ex d

TÜV 09 ATEX 7632X II 2G Ex d IIC T6, II 2D Ex tD A21 IP 65 T80 °C

Process connection, contact tube and float from stainless steel 1.4404

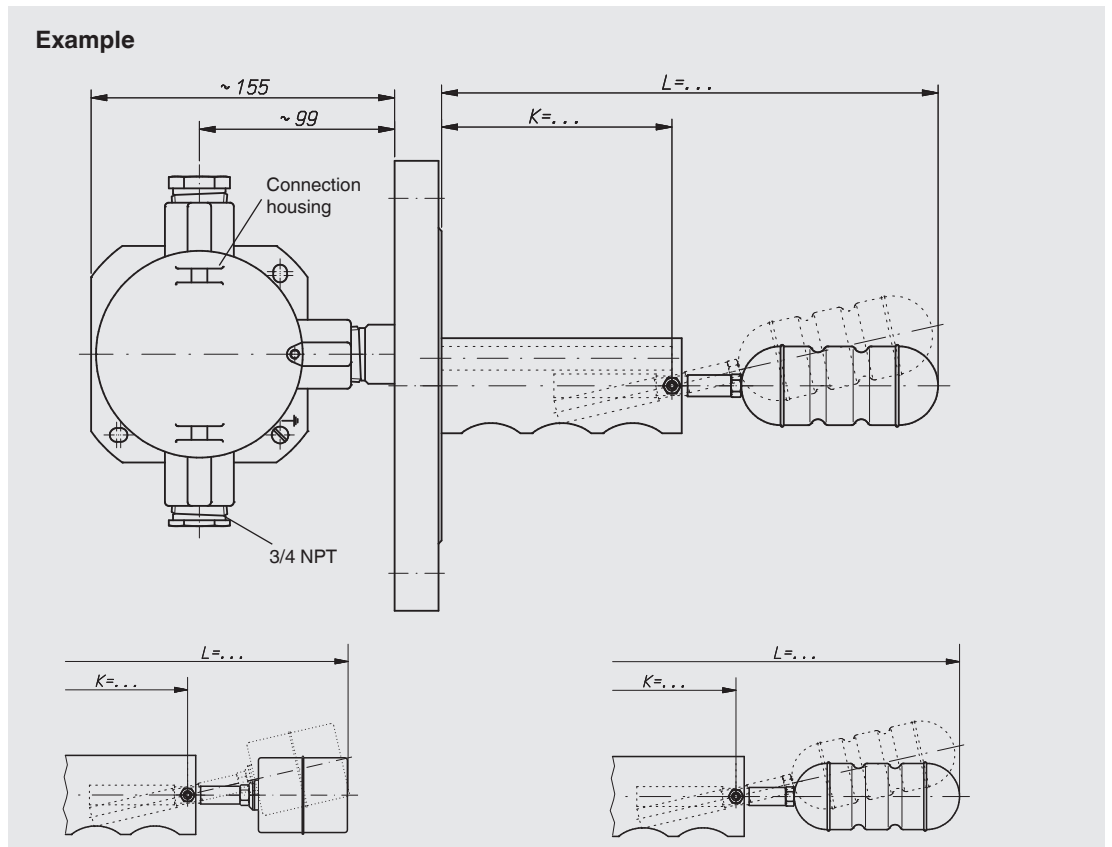

	Float model V44HI	Float model ZVSS43/100HI
Electrical connection	Connection housing ■ Aluminium	
Process connection	Mounting flange ■ EN and DIN DN 65 ... DN 100, PN 6 ... PN 100 ■ ANSI 2,5" ... 4", class 150 ... 600 (other flanges on request)	
Contact tube		
Insertion length L	150 mm	193 mm
Contact tube length K	100 mm	100 mm
Float material	Stainless steel 1.4404	
Float		
Diameter	44 mm	43 mm
Length	52 mm	100 mm
Max. operating pressure	6 bar	20 bar
Min. density	600 kg/m ³	
Temperature range		
Standard	-10 ... +80 °C	
Switching function	1 x change-over SPDT	
Switching power	AC 230 V; 40 VA; 1 A	Please observe contact protection measures!
Mounting position	Horizontal ±30°	
Ingress protection	IP 65 per EN 60529 / IEC 60529	

Magnetic float switch, plastic version, model HLS-P

Process connection, contact tube and float from polypropylene

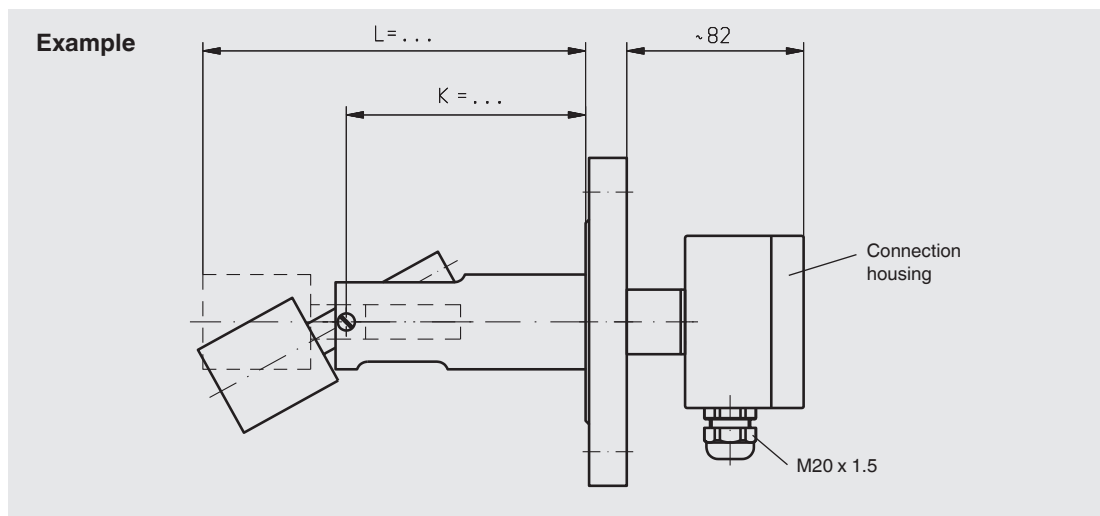

Float model PP44HI

Electrical connection	Connection housing	<input type="checkbox"/> Polypropylene <input type="checkbox"/> Polyester
Process connection	Mounting flange	<input type="checkbox"/> DIN DN 50 ... DN 100, PN 16, form A <input type="checkbox"/> ANSI 2" ... 4", class 150 FF
Contact tube	Insertion length L	176 mm
	Contact tube length K	111 mm
Float material		Polypropylene
Float	Diameter	44 mm
	Length	52 mm
Max. operating pressure		6 bar
Min. density		750 kg/m ³
Temperature range		-10 ... +80 °C
Switching function		selectable: 1 x change-over SPDT 1 x normally open NO - on rising level 1 x normally closed NC - on rising level
Switching power	AC 230 V; 40 VA; 1 A	DC 230 V; 20 W; 0.5 A
	Please observe contact protection measures!	
	Attention: Versions without protective conductor connection - operation only at safety extra-low voltage e.g. contact protection relay or external grounding	
Mounting position		Horizontal ±30°
Ingress protection		IP 65 per EN 60529 / IEC 60529

Electrical connections

Reed contact

1 switch point

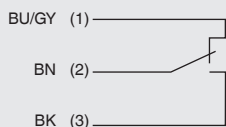

1 switch point
Wiring for operation
with a PLC

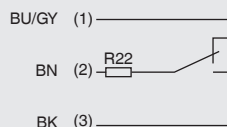

1 switch point
NAMUR circuit per DIN
EN 60947-5-6

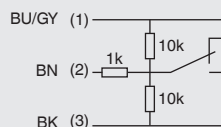

Proximity switch

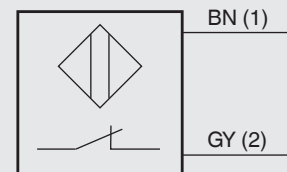

Contact protection measures

The reed contacts should be protected against any voltage or current spikes that might occur.

Depending on the different load types different protective circuits are used.



Model KR 24

RC module

Contact protection relays	Contacts	Input	Power supply	Approval number	Order no.
KR 24	1 x change-over AC 250 V, 2 A	2 x contacts	DC 20 ... 30 V		112941
KR 24-EX	2 x change-over AC 253 V, 2 A	2 x contacts	DC 20 ... 30 V	II 1 GD EEx ia IIC, PTB 02 ATEX 2073	112944
KR 230	1 x change-over AC 250 V, 2 A	2 x contacts	AC 230 V		112942
KR 230-EX	2 x change-over AC 253 V, 2 A	2 x contacts	AC 230 V	II 1 GD EEx ia IIC, PTB 02 ATEX 2073	112943

RC module	Capacitance	Resistance	Voltage	Order no.
B3/115	0.33 μ F	470 Ohm	AC 115 V	110446
B3/230	0.33 μ F	1,000 Ohm	AC 230 V	110460

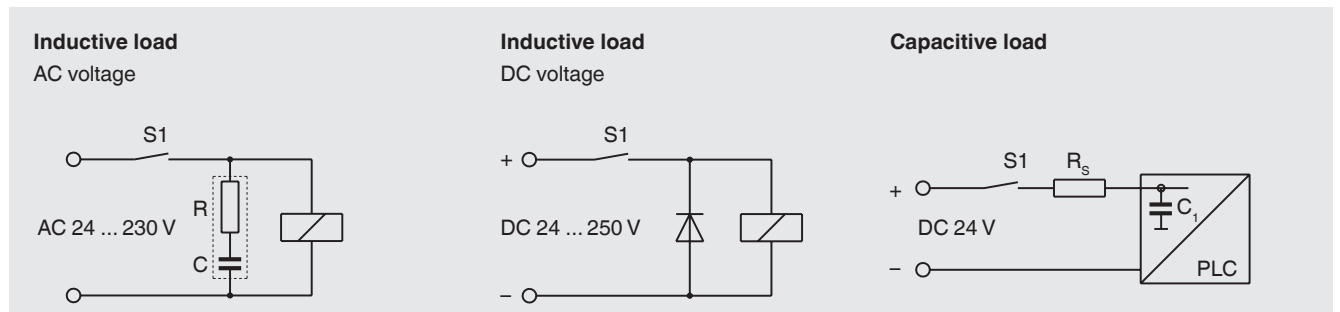

Ordering information

To order the described product the order number (if available) is sufficient.

Alternatively:

Model / Version / Electrical connection / Process connection / Contact tube (insertion length L, contact tube length K) / Options

© 2010 WIKA Alexander Wiegand SE & Co. KG, all rights reserved.
The specifications given in this document represent the state of engineering at the time of publishing.
We reserve the right to make modifications to the specifications and materials.

