

# Series 7100 Flo-Lift® Piston Check Valve

## Award-Winning Design:

Feature-packed valve provides solutions for gas, air or liquid systems



### *The Norriseal Series 7100 Piston Check Valve\**

*is designed for the prevention of backflow in gas, air or liquid systems. Norriseal's expertise in the design of piston balanced control valves has introduced new concepts to the piston check valve industry.*

*The piston check valve, with it's award winning design, has been installed in critical services around the world.*

### Working Pressures

- ANSI 150 thru 2500
- API 5,000 thru 10,000

### Applications

- Air and gas compressor service
- Gas or liquid pipe lines
- Oil and gas production leases
- Pulsating flows
- Safety systems

\* Received the Special Meritorious Award for engineering innovation at the 1981 Offshore Technology Conference in Houston, Texas.

### Features

- Non-slam closing
- No special tool required to change seat
- Low pressure drop
- High Cv values
- Smooth opening
- Special trims for abrasive and corrosive services
- Built-in lifting device for piston removal and inspection
- PTFE self-lubricating piston seal
- Low maintenance costs

### Contents

- 2 Assemblies
- 3 Operation & Installation
- 4 Special Features
- 5 Materials
- 6 Flow Characteristics
- 7 Specifications
- 8 How to Order

Petroleum Engineering  
International



1981

**NORRIS**  
PRODUCTION SOLUTIONS  
A DOVER COMPANY

**NORRISSEAL™**  
A DOVER COMPANY

*Engineered  
Performance*

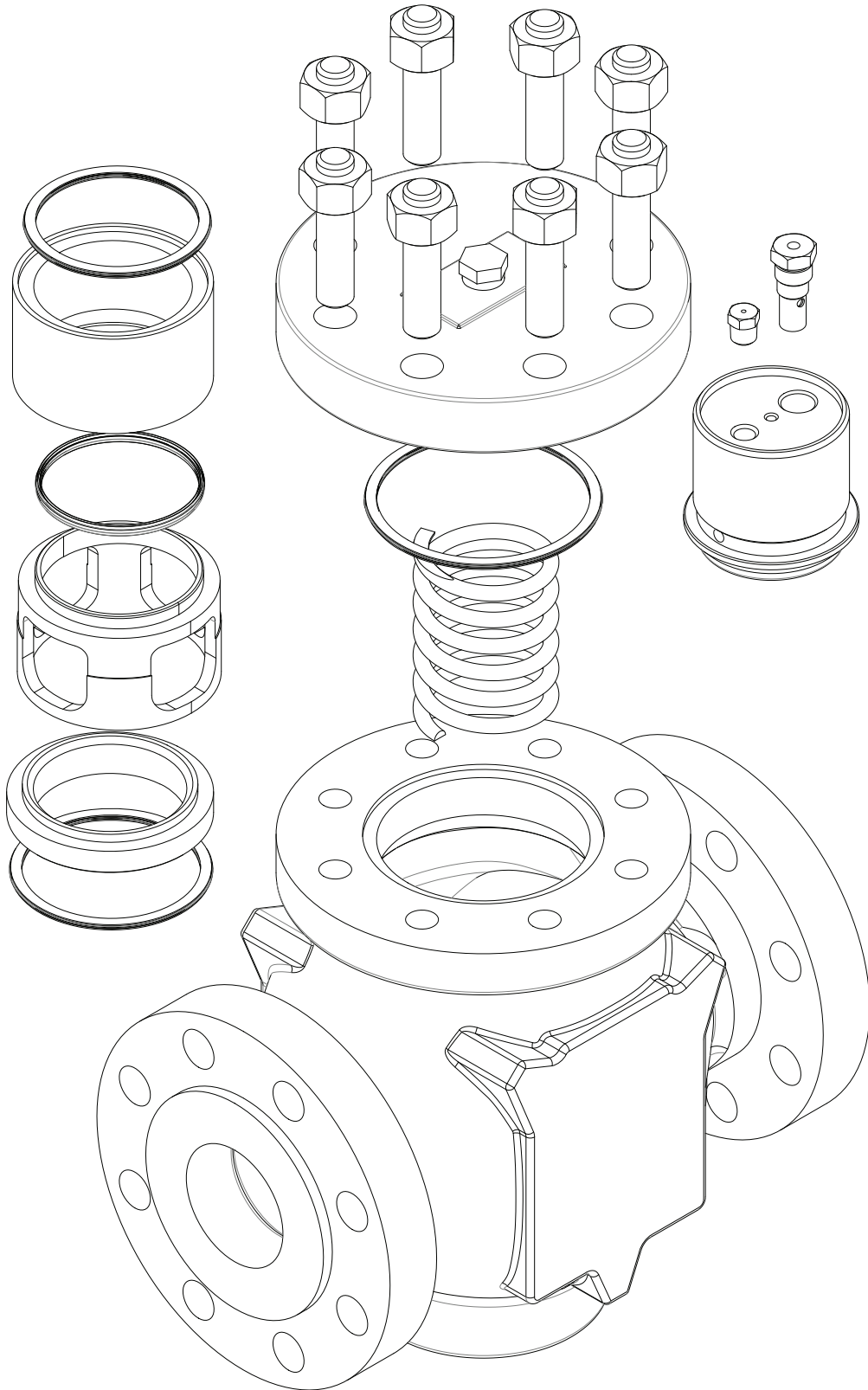

*Valve Assembly*

## Operation

**Normal.** Flow is directed under the valve piston and lifts it upward. When flow is stopped, the piston descends, closing the valve to prevent flow reversal.

**Stabilized/non-slam piston.** Pulsating flow through the valve, if unrestricted, would cause the piston to follow the rapidly cycling line pressure, resulting in vibration, chattering and possibly slamming of the piston. The ball check and orifice plug built into the piston are to prevent this from happening. (Fig. 1)

As the piston rises, the pressure in the PTFE sealed cavity above the piston increases, forcing open the ball check. This reduces the cavity pressure and allows the piston to rise smoothly. As the pressure and flow decrease, the piston moves downward. The ball check closes, and descent of the piston is restricted by fluid flowing through the orifice plug. This equalizes the pressure in the cavity above and below the piston and gives stability to the valve.

## Installation

Valves 4.00" and smaller may be installed in a vertical position. The valve spring should always be installed. Valves installed in a horizontal plane can be used without the valve spring.

## Application

**Compressible fluids.** Valves come with ball-check and orifice plug in piston.

**Non-compressible fluids.** Valves furnished same as for compressible fluids; however, some applications where heavy, viscous liquids are present, the ball check should be removed so piston can stabilize quicker.

**Warning:** 6.00" and larger valves should NOT be installed in a vertical plane. If a vertical plane is required, please consult factory for special accessories.

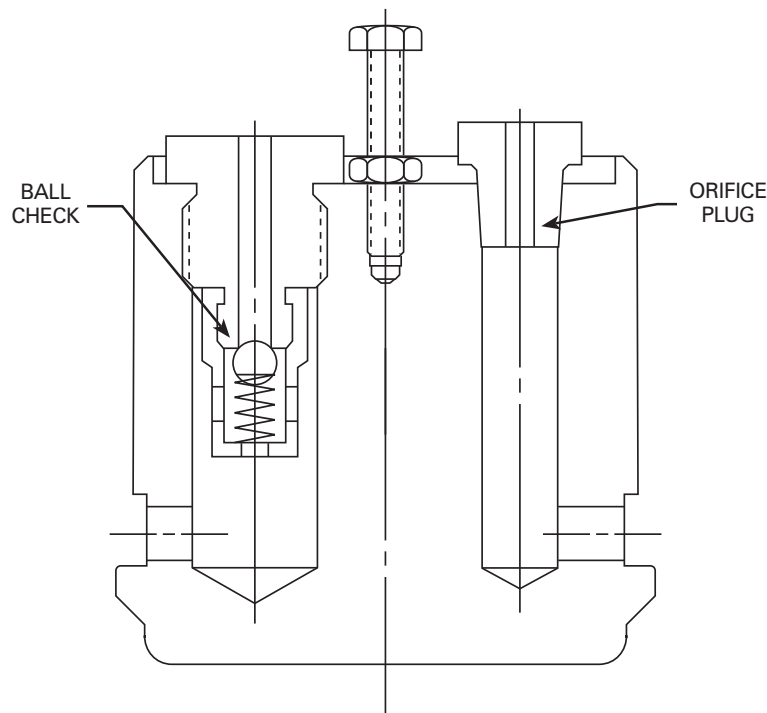

Figure 1

## PTFE Piston Seal Ring

Norriseal's use of a PTFE spring energized seal ring adds a new dimension to the piston check valve. By use of a full circle ring, leakage between piston and guide/cage is zero. Using a low friction, self-lubricating material allows the piston to move freely and quietly without seizing to the seal.

## Guide/Cage

This feature by Norriseal provides positive piston and seat alignment which helps prevent piston vibration and assures stability for proper flow control.

## Valve Spring

Furnished on all standard service valves. This gives an added safety feature for shut-off in all pressure ranges. Valve can operate effectively with spring removed for some applications (see installation section).

## Seat – Non Screwed in Type

Held in position by guide/cage requiring no special tools for removal and can be easily removed by hand.

## Optional Trim

For applications where a positive seal with a zero leakage is required, composition seating material is available. This style piston has the feature of a metal back-up in case of wash-out of the composition trim. (Fig. 3)

Abrasive resistant metal trim sets are available for special applications. Please consult factory. (Fig. 3)

## NACE

Trim available that meets MR0175 recommended practice. (See Materials of Construction)

## Easy Maintenance

Norriseal's valve piston comes with built-in lifting device. No special fittings or tools required to remove piston from valve body.

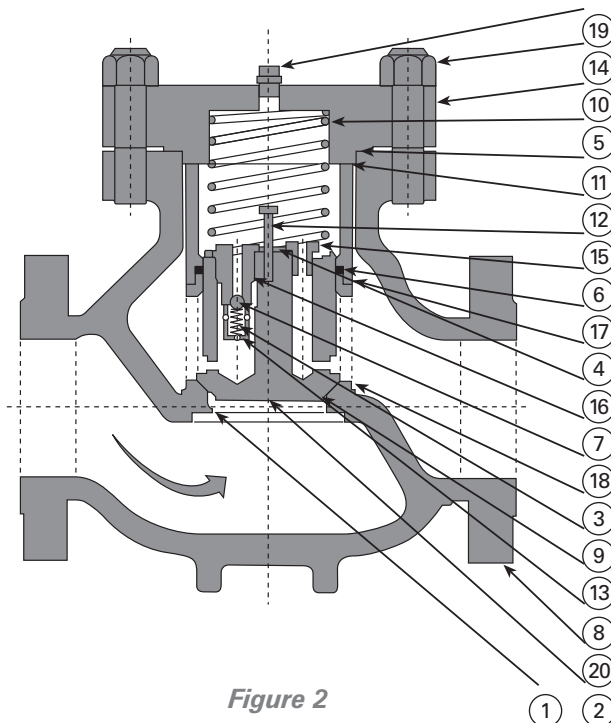

Figure 2

Note: Figure 3 shows piston with replaceable inserted material

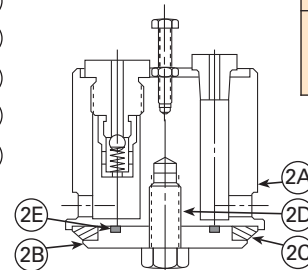

Figure 3

Item No	Description
1	SEAT Valve
2	PISTON Valve Solid
2A	BUTT Piston Valve
2B	RETAINER Piston Valve
2C	INSERT Piston Valve
2D	SCREW Retainer Piston
2E	O-Ring Insert
3	CAGE Piston Valve
4	GUIDE Piston Valve
5	SPRING Valve
6	PLUG Orifice
7	SEAT Ball Check
8	CAGE Ball Check
9	SPRING Ball Check
10	BONNET
11	GASKET Bonnet
12	GASKET Guide
13	GASKET Seat
14	STUD Bonnet w/Nut
15	SCREW Lifting
16	NUT Hex Ring
17	SEAL Piston Guide
18	BALL Check
19	PLUG Pipe
20	BODY

## MATERIALS OF CONSTRUCTION

Item	Valve Size (inches)	Material			
		Standard	NACE MR-01-75	Optional	
Body	1.00 – 12.00	ASTM A216, GR. WCC	ASTM A216, GR. WCC		
Bonnet	1.00 – 12.00	ASTM A516, GR 70 or ASTM A216, GR. WCC	ASTM A516, GR 70 or ASTM A216, GR. WCC	ASTM A351, GR CF8A ASTM A352, GR. LCC	
Valve Piston	1.00 – 4.00	17-4PH SST/H900	316 SST	316 SST	
	6.00 – 12.00	17-4PH SST/H1150-M	17-4PH SST/H1150-M		
Valve Seat	1.00 – 12.00	17-4PH SST/H1150-M	17-4PH SST/H1150-M	316 SST	
Piston Insert (Optional)	1.00 – 4.00	Glass-Filled PTFE	Glass-Filled PTFE	Alloy 6	
	6.00, 8.00	17-4PH SST/H1150-M	17-4PH SST/H1150-M	316 SST or Gls-Fill PTFE	
	10.00, 12.00	17-4PH SST/H1150-M	17-4PH SST/H1150-M	316 SST or C.G.-Fill PTFE	
Insert Retainer	1.00 – 4.00	17-4PH SST/H900	316 SST	316 SST	
	6.00 – 12.00	17-4PH SST/H1150-M	17-4PH SST/H1150-M	316 SST	
Valve Cage	1.00, 2.00, 3.00, 4.00	17-4PH SST/H1150-M	17-4PH SST/H1150-M	316 SST	
	1.50	316 SST	316 SST	17-4PH SST/H1150-M	
	6.00, 8.00	316 SST	316 SST	17-4PH SST/H1150-M	
	10.00, 12.00	17-4PH SST/H1150-M	17-4PH SST/H1150-M	316 SST	
Piston Guide	1.00	17-4PH SST/H1150-M	17-4PH SST/H1150-M	316 SST	
	1.50 – 8.00	316 SST	316 SST	Consult Factory	
	10.00, 12.00	N/A	N/A	N/A	
Piston Seal	1.00	None	None	None	
	1.50 – 8.00	TFE/ELG Ring	TFE/ELG Ring	Fluor.-K/ELG Ring	
	10.00, 12.00	C.G Filled Ring w/Buna-N O-ring	C.G Filled Ring w/Viton O-ring	Consult Factory	
Ball Check Assembly	Seat	1.00	None	None	
		1.50 – 12.00	316 SST	316 SST	Consult Factory
	Cage		316 SST	316 SST	
	Ball		302 SST	302 SST	
Spring	Inconel 600	Inconel 600			
Valve Spring	1.00, 5.00	Inconel 600	Inconel 600	Consult Factory	
	2.00 – 12.00	316 SST	Inconel 600		
Bonnet Studs	1.00 – 12.00	ASTM A193, GR. B7	ASTM A193, GR. B7	Consult Factory	
Hex Nuts	1.00 – 12.00	ASTM A194, GR. 2H	ASTM A194, GR. 2H	Consult Factory	
Spiral Wound Gaskets	1.00 – 12.00	316L SST w/Graphite Filler	Inconel 600 w/Graphite Filler	Consult Factory	
Solid Metal Gaskets (ANS 900 and up)	1.00 – 12.00	316 SST	316 SST	Consult Factory	
Composition Gaskets (Non-ASB)	10.00 (ANSI 150-600)	Synthetic Fiber w/Nitrile Binder	Synthetic Fiber w/Nitrile Binder	Graphite/Fiberglass	
Orifice Plug	1.00	None	None	None	
	1.50 – 12.00	316 SST	316 SST	Consult Factory	
Piston Lifting Attachment	1.00	None	None	None	
	1.50 – 4.00	304 SST	304 SST	316 SST	
	6.00, 8.00	302/304 SST	302/304 SST		
	10.00, 12.00	304/316 SST	304/316 SST		
Nameplate	1.00 – 12.00	316 SST	316 SST	Consult Factory	
Bonnet Vent Plug	1.00 – 12.00	CSTL/ASTM A105	CSTL/ASTM A105	316 SST	
Lifting Attachments (Eye Bolts)	1.00 – 2.00	None	None	None	
	1.00 – 12.00	Forged Alloy Steel	Forged Alloy Steel	Consult Factory	



## BODY FACE-TO-FACE DIMENSIONS "F" (INCHES)\*

Body Size	End Connection Type									
	NPT <sup>+</sup>	Butt-weld <sup>+</sup>	Socket-weld <sup>+</sup>	Flange Type	ANSI Flanged					
					150	300	600	900	1500	2500
1.00	8.25	8.25	8.25	RF	7.25	7.75	8.25	9.38	9.38	N/A
				RTJ	7.75	8.25	8.25	9.38	9.38	N/A
1.50	13.00	13.00	13.00	RF	8.75	9.25	9.88	12.25	12.25	N/A
				RTJ	9.25	9.75	9.88	12.25	12.25	N/A
2.00	11.25	11.25	11.25	RF	10.00	10.00	11.25	14.75	14.75	16.88
				RTJ	10.50	11.12	11.38	14.88	14.88	17.00
3.00		CF	CF	RF	11.75	12.50	13.25	15.50	18.12	22.75
				RTJ	12.25	13.12	13.38	10.62	18.25	23.00
4.00		CF	CF	RF	13.38	14.50	15.50	17.00	20.88	26.50
				RTJ	14.38	15.12	15.62	17.12	21.00	26.88
6.00		CF		RF	17.75	18.62	20.00	24.00	27.75	36.00
				RTJ	18.25	19.25	20.12	24.12	28.00	36.50
8.00		CF		RF	21.38	22.38	24.00	29.00	32.75	40.25
				RTJ	21.88	23.00	24.12	29.12	33.12	40.88
10.00		CF		RF	24.50	24.50	31.00	33.00	39.12	C/F
				RTJ	25.00	25.12	31.12	33.12	39.38	C/F
12.00		CF		RF	29.00	30.50	32.25	40.00	44.50	C/F
				RTJ	29.38	31.00	32.38	40.12	45.12	C/F

\* For face-to-face dimensions other than those listed above, ie. API 6D, please consult factory  
 + ANSI 1500 C.L. Pressure Rating

## BODY HEIGHT DIMENSIONS

Valve Size	ANSI Class	"D"	"E"
1.00	150-1500	7.75	3.06
1.50	150-600	9.75	3.50
	900-1500	10.50	4.00
2.00	150-1500	12.12	4.38
	2500	15.12	5.25
3.00	150-900	13.50	5.50
	1500	16.88	6.25
	2500	20.75	6.50
4.00	150-900	18.75	7.00
	1500	19.38	7.50
	2500	23.12	7.62
6.00	150-600	20.75	7.50
	900-1500	25.00	8.62
8.00	2500	30.00	10.50
	150-600	26.50	9.00
10.00	900	27.88	10.38
	1500 & 2500	39.00	12.75
	150-600	34.00	11.63
12.00	900	36.25	11.94
	1500	39.75	13.00
	150-300	37.12	12.00
	600	38.50	12.75
12.00	900	40.12	13.50
	1500	43.59	14.75

\* For 10.00" and 12.00" ANSI 2500 Class C/F

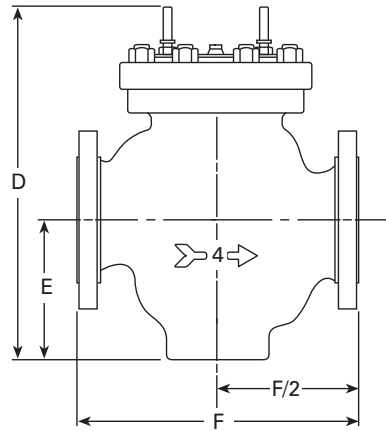

## STANDARD BODY END CONNECTIONS\*\*

Body Size	NPT	Butt Weld	Socket Weld	Flanged (ANSI Ratings)
1.00	*	*	*	150-1500
1.50	*	*	*	150-1500
2.00	*	*	*	150-2500
3.00		*	*	150-2500
4.00		*	*	150-2500
6.00				150-2500
8.00				150-2500
10.00				150-2500
12.00				150-2500

\*\*For valve body end connections other than those listed and higher pressure ratings, please consult factory.

# How to Order

1. Determine required body size
2. Use model number code below as illustrated to select proper valve type to suit operating conditions.

BODY RATING	
ANSI	Code
150	02
300	07
400	09
600	14
900	21
1500	36
2500	60
5000	50 <sup>1</sup>
10,000	100 <sup>1</sup>

<sup>1</sup>API rated working pressure

BODY CONNECTIONS	
Type	Code
Screwed (Female) NPT	S
ANSI Flanged Raised Face	RF
ANSI Flanged Ring Type Joint	RJ
Beveled Buttweld	B <sup>#</sup>
Socketweld	W <sup>#</sup>
API Flanged Ring Type Joint	AF

<sup>#</sup>Specify schedule

SERVICE CODE	
Body, Bonnet	Code
WCC Standard (General Serv.)	-
WCC NACE Spec. (MR0175)	N
316 SST	S

VALVE SPRING MATERIAL	
Type	Code
316 SST (Horizontal)	R
Inconel (Horizontal)	L <sup>*</sup>
No Spring	0
316 SST (Vertical)	V
Inconel (Vertical)	W <sup>*</sup>

BODY CONFIGURATION	
Configuration	Code
Norriseal F-F (ISA)	-
Non-Std. F-F (Not ISA or API)	C <sup>2</sup>

<sup>2</sup>Consult factory for non-standard F-F applications

Please note: not all available options are shown.

BODY STYLE	
Code	Flow Pattern
D	Globe w/Bottom Drain (Standard 10" and larger)
G	Globe w/o Bottom Drain (Standard 8" and smaller)

GASKETS (SPIRAL WOUND)	
Code	Fluid
S	316 SST/Grafoil
N	Inconel 600/Grafoil

FLUID TYPE	
Code	Fluid
A	Gas or Air
B	Liquid

PISTON SEAL MATERIAL	
Code	Material
E	PTFE/Elgiloy
F	Buna w/TFE Rider (>8.00")
G	Viton w/TFE Rider (>8.00")
K	Fluoroloy K (>8.00")
J	Carbon-Graphite
O	No Seal (1.00")

TRIM MATERIAL				
Code	Piston	Seat	Cage	Guide
A	17-4PH	17-4PH	17-4PH	17-4PH
B <sup>*</sup>	316 SST	17-4PH	17-4PH	17-4PH
C <sup>*</sup>	316 SST	316 SST	316 SST	316 SST
E <sup>*</sup>	316/STEL	316/STEL	316 SST	316 SST
G	17-4/TFE	17-4PH	17-4PH	316 SST
J <sup>*</sup>	316/TFE	17-4PH	17-4PH	17-4PH
L <sup>*</sup>	316/TFE	316 SST	316 SST	316 SST
T	17-4/TFE	17-4PH	17-4PH	17-4PH
Z	17-4/UHMW	17-4PH	17-4PH	17-4PH

<sup>\*</sup>NACE MR0175 Suitable

## S - 36RGS - AEA



Engineered Performance

11122 West Little York • Houston, Texas 77041

Tel: 713-466-3552 • Fax: 713-896-7386

www.norriseal.com

Please contact your Norriseal representative for more details and assistance in specifying the optimal solution for your application.