

Quadrant[®]

VALVE & ACTUATOR, LLC

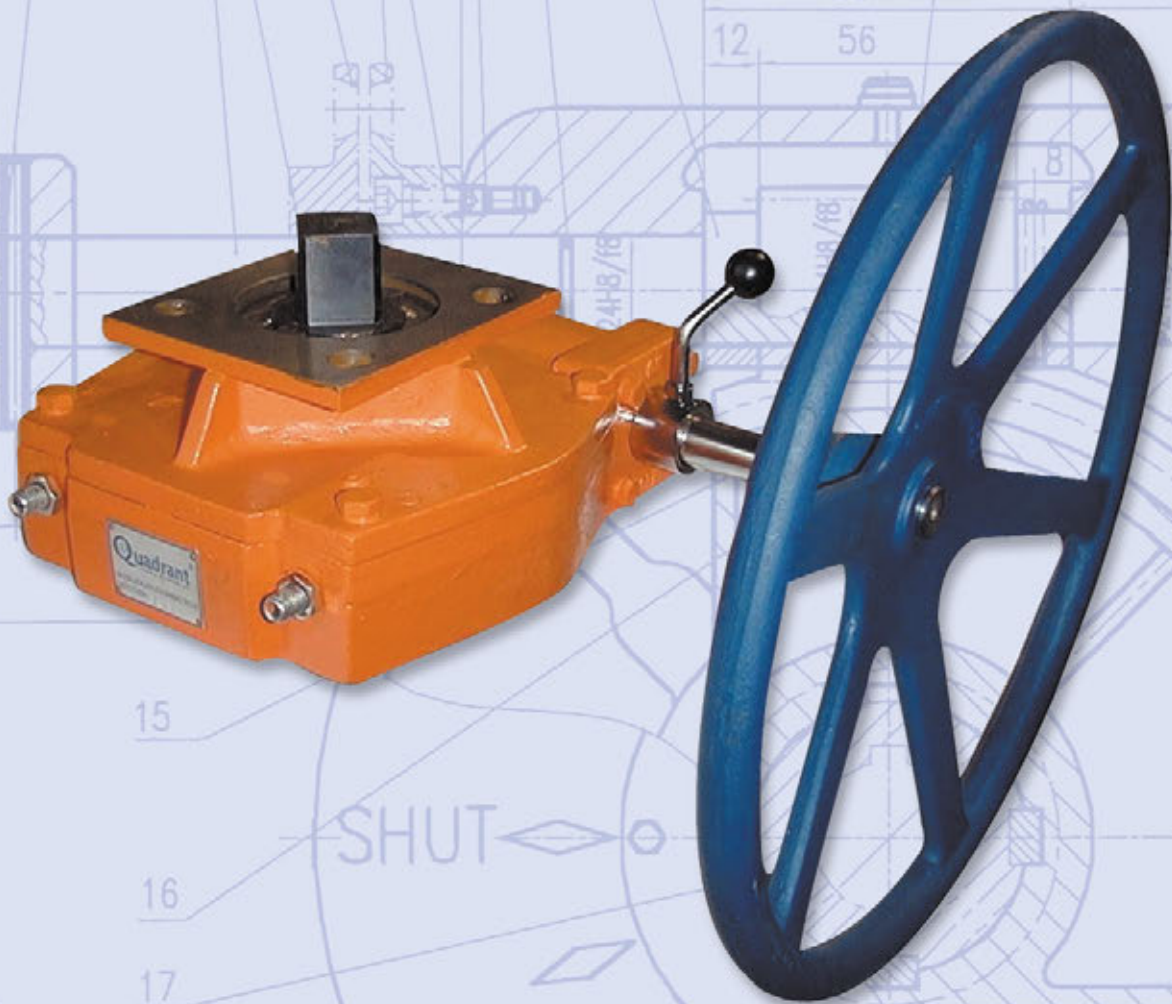

**DECLUTCHABLE WORM GEAR
ACTUATORS
& MANUAL OVERRIDES**

FEATURES



- ISO 5211 Compliant upper and lower mounting patterns
- ISO 5211 Compliant upper male square drive and female "double-square" lower drive
- Dual position limit stops
- Low profile design provides minimum actuated valve package height
- Retained male input drive provides direct mount to ISO-compliant actuators without adapters
- External lube fitting
- Roller thrust bearings on worm gear for improved efficiency

MATERIALS OF CONSTRUCTION

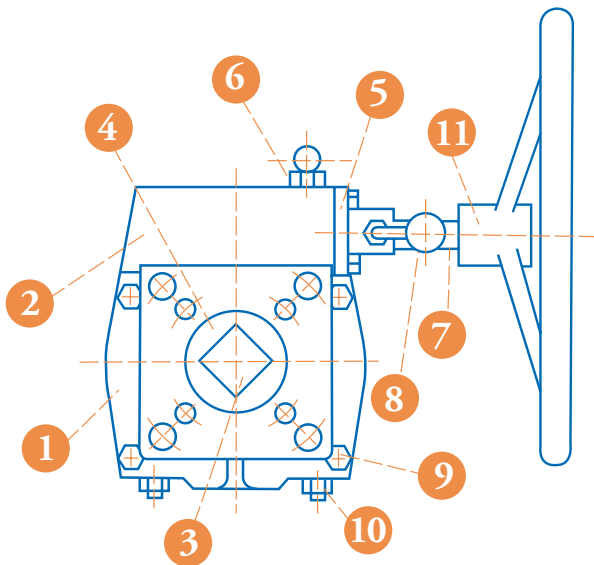

PART	QTY.	DESCRIPTION	STANDARD MATERIAL
1	1	COVER	CAST IRON
2	1	BODY	CAST IRON
3	1	INPUT SHAFT	PLATED CARBON STEEL
4	1	QUADRANT GEAR	DUCTILE IRON
5	1	GEAR COVER	CAST IRON
6	1	POSITION LOCK ASSY.	PLATED CARBON STEEL
7	1	HANDWHEEL SHAFT	PLATED CARBON STEEL
8	1	POSITION LEVER ASSY.	PLATED CARBON STEEL
9	4	COVER BOLTS	PLATED CARBON STEEL
10	2	LIMIT STOPS	PLATED CARBON STEEL
11	1	HANDWHEEL	CAST IRON
Not Shown	2	SHAFT BUSHINGS	CARBON STEEL
Not Shown	4	GEAR COVER BOLTS	PLATED CARBON STEEL
Not Shown	1	WORM GEAR & SHAFT	PLATED CARBON STEEL
Not Shown	1	GREASE FITTING	PLATED CARBON STEEL
Not Shown	1	NAMEPLATE	ALUMINUM
Not Shown	4	O-RINGS	BUNA-N

PERFORMANCE TABLE

Operator	Gear Ratio	Mechanical Advantage	Weight (Lbs.)	Maximum Torque Rating (In-Lbs.)	External Failure Torque (In-Lbs.) (Note A)	Internal Failure Torque (In-Lbs.)	Output Torque (In-Lbs.) with 80 Lbs. Rimforce (Std. Handwheel)
DG6	26:1	5.6:1	11	3,000	3,100	> 4,000	2,568 In-Lbs
DG8	38:1	8.4:1	17	4,425	4,700	> 7,500	4,032 In-Lbs
DG11	53:1	11.3:1	27	8,850	14,000	> 15,000	5,424 In-Lbs
DG15	80:1	14.6:1	55	17,700	24,000	> 26,500	10,440 In-Lbs
DG15A	80:1	14.6:1	56	17,700	24,000	> 26,500	10,440 In-Lbs
DG17	77:1	17.1:1	76	17,700	29,000	> 44,000	12,312 In-Lbs

Note A: Handwheel pin supplied with unit must be used.

DG6 to DG 15

CONSTRUCTION AND DIMENSIONS

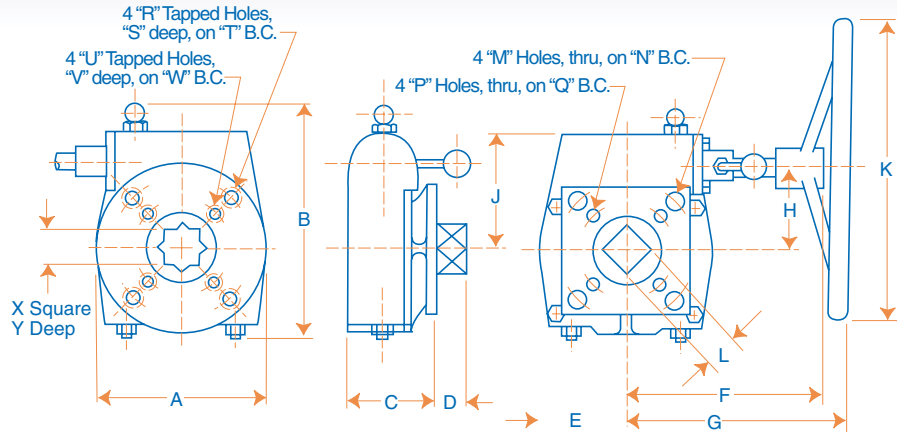

DG15A and DG 17

CONSTRUCTION AND DIMENSIONS

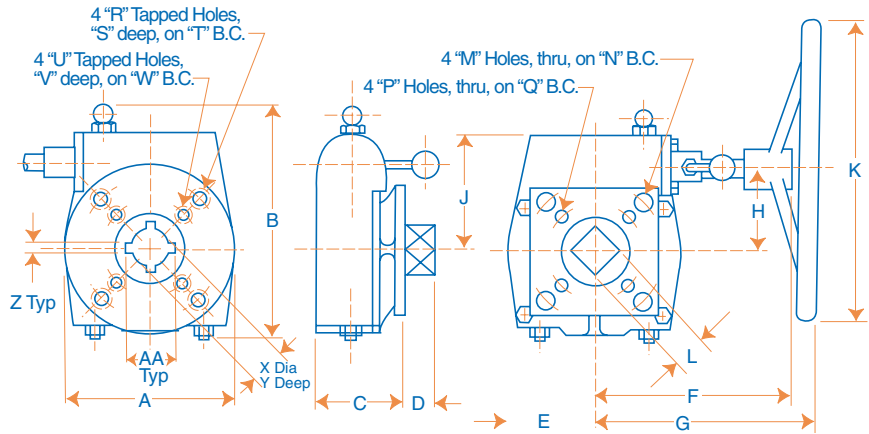

DIMENSIONS

OPERATOR	A	B	C	D	E	F	G	H	J	K	L	M (DIA)	N (DIA)
DG6	4.30	6.70	3.10	0.47	2.15	6.45	7.6	1.75	3.25	12.0	11MM	0.35	2.76
DG8	5.02	7.60	3.18	0.70	2.51	7.70	8.9	2.60	3.80	12.0	17MM	0.47	4.02
DG11	7.00	9.30	3.44	0.95	3.50	8.20	9.4	3.45	4.70	12.0	22MM	0.55	4.92
DG15	9.40	12.10	4.55	1.14	4.70	9.60	10.9	4.83	6.48	18.0	27MM	0.55	4.92
DG15A	9.40	12.10	4.61	1.50	4.70	9.60	10.9	4.83	6.48	18.0	36MM	0.71	5.51
DG17	11.10	13.80	4.81	1.50	5.55	9.30	10.6	5.60	7.40	18.0	36MM	0.71	5.51

OPERATOR	P (DIA)	Q (DIA)	R	S	T (DIA)	U	V	W (DIA)	X	Y	Z	AA	ISO PATTERN(S)
DG6	0.28	1.97	M8-P1.25	0.50	2.76	M6-P1.0	0.35	1.97	14MM	1.30	N/A	N/A	F05/F07
DG8	0.35	2.76	M10-P1.5	0.59	4.02	M8-P1.25	0.50	2.76	17MM	1.30	N/A	N/A	F07/F10
DG11	0.47	4.02	M12-P1.75	0.71	4.92	M10-P1.5	0.59	4.02	27MM	1.81	N/A	N/A	F10/F12
DG15	N/A	N/A	M12-P1.75	0.71	4.92	N/A	N/A	N/A	27MM	1.81	N/A	N/A	F12
DG15A	N/A	N/A	M16-P2.0	0.94	5.51	N/A	N/A	N/A	2.375DIA	2.09	0.500	2.93	F14
DG17	N/A	N/A	M16-P2.0	0.94	5.51	N/A	N/A	N/A	2.375DIA	2.60	0.500	2.93	F14

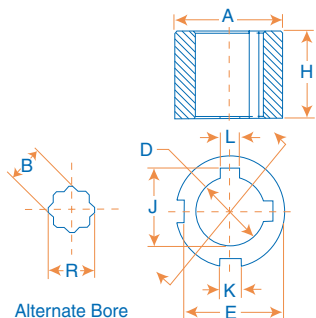

DG15A & DG17 INSERTS

INSERT	FOR:	A (DIA)	B	D (DIA)	E	H	J	K	L	R
DG17-25MMDIA	DG15A & DG17	2.374/2.371	N/A	0.985	2.156	2.00	N/A	.500/.502	N/A	N/A
DG17-27MMSQ	DG15A & DG17	2.374/2.371	1.063/1.068	N/A	2.156	2.00	N/A	.500/.502	N/A	1.425
DG17-33DIA	DG15A & DG17	2.374/2.371	N/A	1.313/1.315	2.156	2.00	1.455	.500/.502	.313/.315	N/A
DG17-38DIA	DG15A & DG17	2.374/2.371	N/A	1.500/1.502	2.156	2.00	1.670	.500/.502	.375/.377	N/A
DG17-41DIA	DG15A & DG17	2.374/2.371	N/A	1.625/1.628	2.156	2.00	1.796	.500/.502	.375/.377	N/A

Quadrant[®]

VALVE & ACTUATOR, LLC

SERIES DG6 - DG17

NUMBERING SYSTEM ... HOW TO ORDER:

DG6

UNIT NUMBER
 DG6
 DG8
 DG11
 DG15
 DG15A
 DG17

F05/F07

UPPER & LOWER
 ISO PATTERNS
 DG6 = F05/F07
 DG8 = F07/F10
 DG11 = F10/F12
 DG15 = F12
 DG15A = F14
 DG17 = F14

11MM/14MM

TOP MALE SQUARE
 DG6 = 11MM
 DG8 = 17MM
 DG11 = 22MM
 DG15 = 27MM
 DG15A = 36MM
 DG17 = 36MM

LOWER FEMALE
 DOUBLE SQUARE
 DG6 = 14MM
 DG8 = 17MM
 DG11 = 27MM
 DG15 = 27MM
 DG15A = 2.38D
 DG17 = 2.38D

12

HANDWHEEL DIA.
 DG6 = 12"
 DG8 = 12"
 DG11 = 12"
 DG15 = 18"
 DG15A = 18"
 DG17 = 18"

**DG11 on 10"
 BFV-A**

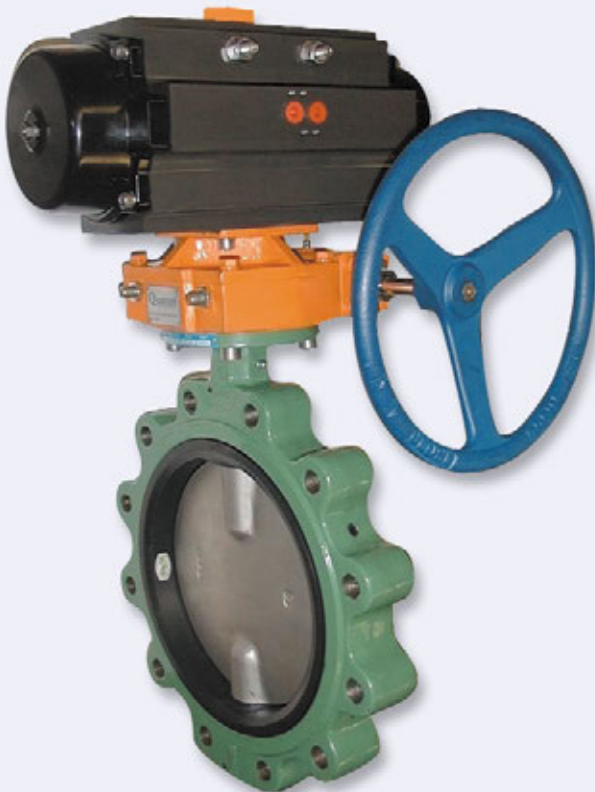

**DG8 on 3"
 F2-SS**