

# ASHCROFT®

## Test Gauges



**ISO 9001**  
REGISTERED FIRM

**DRESSER** INSTRUMENT

A Halliburton Company

BULLETIN TG-2

# Features & Benefits

## Ashcroft® Test Gauges

Dresser engineers have developed a new generation of test gauges to meet the exacting needs of instrument engineers and quality specialists. The new Ashcroft® test gauge can be used as a transfer standard for periodically checking the accuracy of pressure instruments or as a laboratory instrument for research and test labs. The wealth of new features make it an excellent test gauge for process applications where high accuracy in pressure measurement is essential.

- External adjustable dial facilitates compensation for tare or zero adjustment on standard case style Type 1082(\*)S only.
- Temperature compensated movement that significantly reduces temperature error.

Conventional test gauge accuracy is adversely affected as the ambient temperature varies from that at which the gauge was calibrated. This inaccuracy can be as much as 0.02%/°F or ½% for a 25°F temperature change. The 4½" and larger Ashcroft test gauges include a special bimetallic element which automatically reduces ambient temperature errors to less than 0.005% per degree F.

Some manufacturers reduce temperature error by using NiSpan C® for bourdon tubes. This material is subject to serious corrosion problems in some applications. The Ashcroft temperature compensated movement allows use of Monel® bourdon tubes for corrosion resistance superior to NiSpan C while still providing excellent temperature stability.

\*Bourdon tube designation (see page 4).

- MicroSpan™ adjustment for ease in span calibration. This device permits precise adjustments to achieve exact span calibration from 0 to 100% of scale. The micrometer screw attached to the slide will vary the span by approximately ½% per 360° rotation.
- The long life bourdon tube is capable of sustained accuracy, yet is suitable for process applications. The Ashcroft test gauge uses the Ashcroft Duragauge® pressure gauge bourdon tube – perhaps the most highly developed bourdon tube in the world. Proven and refined by years of rugged service in demanding process applications around the world, this outstanding pressure element is standard in all 4½", 6" and 8½" size Ashcroft test gauges.
- Hydraulically staked movement provides improved stability. The movement, with Teflon® coated gears and bearings, uses a unique hydraulic staking operation to ensure a rigid movement frame that resists shift due to shock and vibration. High and low pressure movement stops are standard to protect the gauge against calibration shifts caused by accidental overpressure, and to limit pointer rotation.
- Improved dial and pointer results in excellent readability. Larger numerals, additional graduations and a highly polished mirror band



Standard Case Style  
Type 1082 (\*)S

FRONT VIEW

## CONTENTS

Introduction . . . . .	2
Standard Case Styles . . . . .	4
Optional Case Styles . . . . .	5
Accessories and Optional Features . . . . .	6
Product Selection Information . . . . .	7
To Order a Gauge . . . . .	8
Standard Ranges . . . . .	9
Gauge Case Dimensions . . . . .	10-11

combined with a knife edge pointer with red painted tip to allow precision readability that eliminates parallax error.

- Test gauges are built in a modern manufacturing environment. Assembly, calibration and inspection are performed in a climate controlled manufacturing cell to ensure consistent product quality. Computer set pressure standards give accurate calibration that is traceable to NIST (National Institute of Standard & Technology – formerly NBS).

A skilled technician is responsible for building, calibrating and final inspection of each test gauge. The technician's signature attached to the gauge guarantees ASME B40.1, Grade 3A (0.25%) full scale accuracy.

- The standard test gauges are now available from stock. The new standard 4½", 6" and 8½" 1082 gauge line is supplied with solid front case for safety. Corrosion resistant black epoxy finish is standard.



Temperature compensator reduces temperature-caused errors to less than 0.005% per °F temperature change.

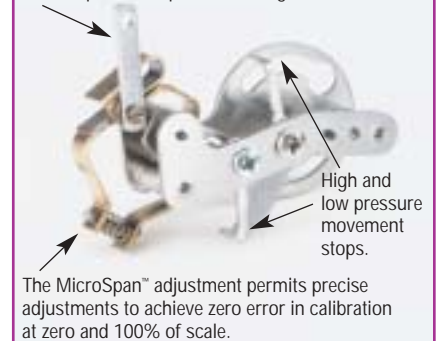

BACK VIEW  
(pressure relief back – removed)

# Ashcroft® Test Gauges



Adjustable tabs can be set to each cardinal point providing a higher degree of accuracy.



SPECIFICATIONS	TYPE 1080(*)S	TYPE 1084	TYPE 1082(*)S
Accuracy %/Grade	±0.25/ASME B40.1, Grade 3A	0.5/ASME B40.1, Grade 2A	0.25/ASME B40.1, Grade 3A
Dial Size	8½"	3"	4½", 6", 8½"
Tube and Socket Material	(P) Monel Tube and Socket	(S) 316 St. St. Welded	(A) Phosphor Bronze Tube, Brass Socket (P) Monel Tube and Socket
Case Material	Aluminum, Solid Front, with Handle Black Epoxy Coated	Polished St. St. - Open Front <sup>(1)</sup>	Aluminum, Solid Front, Black Epoxy Coated
Movement	400 Series St. St. Rotary Design Teflon <sup>(2)</sup> S Coated Bearings Micrometer Span Adjustment – Bimetallic Temp. Compensator (.005%/per °F Max. Temp. Error)	Precision, St. St. with Teflon "S" Coated Bearings and Pinion	400 Series St. St. Rotary Design Teflon <sup>(2)</sup> S Coated Bearings Micrometer Span Adjustment – Bimetallic Temp. Compensator (.005%/per °F Max. Temp. Error)
Mounting and NPT Connection Location	Stem Mounting ¼" NPT Lower <sup>(4)</sup>	¼" NPT Lower Only	Stem or Flush Mounting <sup>(3)</sup> ¼" Lower or Back <sup>(4)</sup>
Ranges and Bourdon Tube Selection	Vac/10,000 psi – (P) K Monel	Vac/1000 psi	Vac/400 psi – (A) Phosphor Bronze Vac/10,000 psi – (P) K Monel
Ring	Hinged Steel – Black Wrinkle Finish	Bayonet Cam – Lock Polished Stainless Steel	Hinged Steel – Black Wrinkle Finish
Window	Glass	Polycarbonate	Glass
Pointer	Balanced Friction Adjustable with Red Knife-Edge Tip	Black Aluminum with Red-Painted Knife-Edge Tip	Black Aluminum with Red-Painted Knife-Edge Tip
Dial	White Background, Black Graduations with Polished Mirror Band	Zero Adjustable Aluminum, White Background, Black Numerals with Polished Mirror Band	Externally Adjustable, Aluminum, Black Numerals with Polished Mirror Band
Weatherproof	No	Yes	No
Options	See Page 6	See Page 6	See Page 6

\*Bourdon tube designation

(1) For optional polished stainless steel protective cover, specify part. #302B198-01  
(2) Registered TM of DuPont Co.

(3) Cases supplied with studs for flush mounting.  
(4) Optional connection ½" NPT

These special case types include all the features of the standard test gauge with the exception of the external adjustable dial.

## Optional Type1082 Case Styles

### CASE TYPE XAY

This is a solid front aluminum case with a back flange. It has a threaded black polypropylene ring. This case is weatherproof and is black epoxy finished to stand up well under most environmental conditions. It can be stem, surface or flush mounted and is available in 4½" and 6" dial sizes with lower or back connection.



### CASE TYPE XAZ

This rugged, solid front aluminum case has a threaded aluminum front ring. Both case and ring have a black epoxy finish. This case style has no back flange. It is a durable weatherproof case with an epoxy finish that stands up well to most environmental conditions. It is available with lower or back connection, in 4½" dial size only.



### CASE TYPE XTY

This is a solid front black phenolic turret case with a threaded black polypropylene ring. It is lightweight, weatherproof and offers a high resistance to corrosion and most environmental conditions. It can be stem, surface or flush mounted and is available with lower or back connection, in 4½" dial size only.



### CASE TYPE XQY

This unique design is a solid front black polypropylene, fiberglass reinforced impact resistant case with bayonet ring. It can be stem, surface or flush mounted with lower or back connection, in 6" dial size only.



# Accessories

Ashcroft® Test Gauges

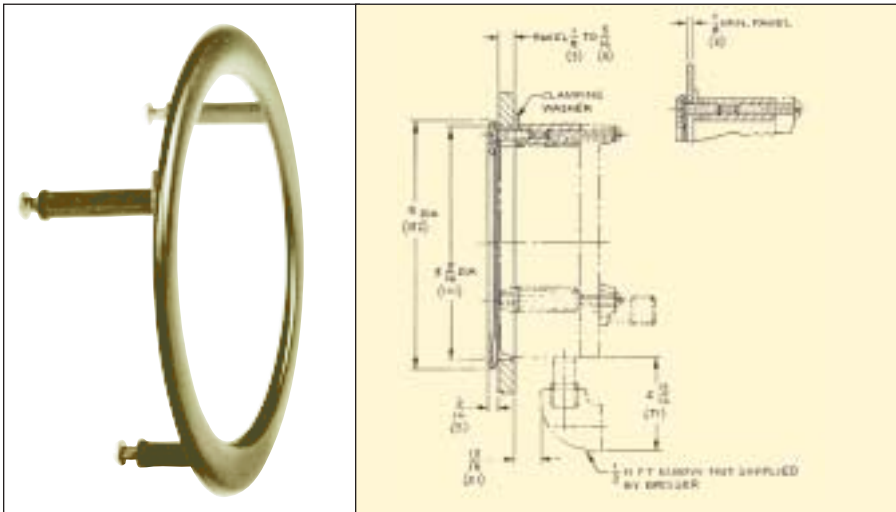

## TYPE 1278M FLUSH MOUNTING RING

The flush mounting ring is used to flush mount gauge case type XTY and XAY. Standard finish is black. Polished stainless steel finish is available for an extra charge.

Gauge Size (Inches)	Ring O.D. (Inches)	A Diameter (Inches)	"B" – Three Screws
			Size
4½	6.000	5 <sup>37</sup> / <sub>64</sub>	#10-24 x 7/8"
6	7.765	7¼	¼-20 x 1½"



## GAUGE TOOL KIT

Complete kit for gauge maintenance. Includes hand jack, set screw driver, five reamers, two pin vise holders, wiggler and tweezers all packed in a neat carrying case. Ideal for a gauge maintenance shop.

## THROTTLING DEVICES

The throttling device should be used when a pressure gauge is subjected to rapid pressure fluctuations, which make the gauge difficult to read because of rapid pointer movement. Such a device reduces pressure impact, slows the speed and range of pointer movement, and



## HAND JACK SET

Gauge pointer remover and a pointer set, to secure pointer to the shaft.



## TIP BLEED

The tip bleed allows trapped air to be removed from the bourdon tube. It is also used for back flushing or cleaning the system. The tip bleed is limited to 4½", 6" and 8½" solid front cases with bronze tube systems only up to 400 psi.



## OPTIONAL WINDOWS

- Acrylic** – Optional for glass window.
- Laminated Safety Glass** – Optional for glass window.
- Non-Glare Glass** – Optional for glass window.

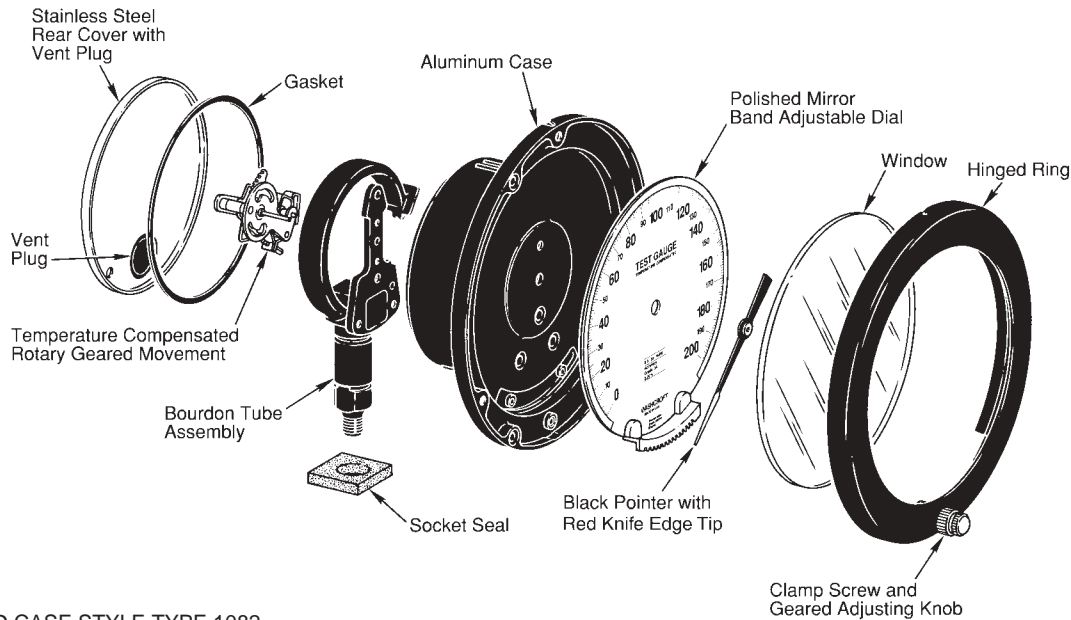

STANDARD CASE STYLE TYPE 1082

### Consult ASME B40.1 for guidance in gauge selection

**WARNING:** Pressure gauges should be selected considering media and ambient operating conditions, to prevent misapplication. Improper application can be detrimental to the gauge, causing failure and possibly personal injury or property damage.

The information contained in this catalog is offered as a guide to assist in making the proper selection of a test gauge.

**Pressure Ranges:** For process applications, select a gauge with a full scale pressure range of approximately twice the normal operating pressure. The maximum operating pressure should not normally exceed 75% of the full range. For laboratory applications, where cycling is less frequent, the range of the test gauge may be the same as that of the instrument under test.

**Operating Conditions:** To ensure long life and accurate readings, pressure gauges should not be exposed to process or ambient temperatures over 150°F. This is especially true of gauges with liquid filled cases due to thermal expansion of the case fill fluid. Long term exposure to temperatures in excess of 150°F may cause discoloration of dials and fill fluids, as well as hardening of elastomeric case seals and possible fill leakage. Soft soldered, silver brazed and welded pressure

joints are rated at 250°F maximum, 450°F maximum and 750°F maximum respectively. Plastic gauge cases, including phenolic should not be exposed to temperatures in excess of 250°F. Accuracy of temperature compensated Type 1082 gauges will be affected by approximately 0.005% per degree F and accuracy of all other test gauges will be affected by approximately 0.015% per degree F.

**Cases:** Six different case styles and three different materials are offered – aluminum alloy, fiberglass reinforced polypropylene, and phenolic. Two types are offered, open and solid front. The open front Type 1084 case is constructed with the dial between the bourdon tube and the window, with a pressure relief opening between the socket and the case. The solid front cases supplied on all other test gauges provide increased safety with a solid wall between the bourdon tube and the window. The entire rear of the gauge is covered with a stainless steel pressure relief back. Should the Bourdon tube fail due to overpressure, corrosion or fatigue, the wall directs pressure buildup through the rear of the case and away from the dial and the window.

**Bourdon Tube Pressure Elements:** Available for a wide variety of media applications; materials include phosphor bronze and K-Monel®.

**Movement:** All gauges 4½" size and larger feature a rotary geared movement, the most efficient and positive method of transmitting mechanical motion. Moving

parts are designed and protected to reduce friction and wear. All movements are ultrasonically cleaned and lubricated to guarantee smooth operation and to resist wear associated with high vibration and/or pulsation. Span, linearity, and zero adjustments are easily made to assure continued accuracy of all Ashcroft test gauges.

**Dials:** Aluminum dials have highly legible black markings on a white background. Each test gauge dial has a mirror band which eliminates parallax errors when the pointer and its reflection are aligned. External adjustable dial available in standard case style 1082(\*)S.

**Pointers:** Balanced knife-edge tip pointers, supplied with all test gauges, allow precise and easy readings. All are lightweight to maintain a high standard of accuracy. Type 1082 and 1084 pointers include a red tip for enhanced readability.

**Windows:** The standard window for Type 1080 and 1082 test gauges is glass. Non-glare glass is optional. Acrylic windows, also optional, are more resistant to impact breakage than glass windows. Safety glass, also optional, will not fracture into many pieces as will ordinary glass. Window for Type 1084 is polycarbonate.

**Rings:** The ring, which retains the window, is threaded, bayonet (cam) or hinged, depending upon case type. All Type 1082 windows have a gasket to protect the internal mechanism from outside environments.

# How to Order

## Ashcroft® Test Gauges

### Select:

- Case Type – Table A
- Dial Size – Table A
- Bourdon System (\*) Ordering Code – Table B
- Connection: Location – Table A; Size – Table B
- Optional Case Selection – Table A
- Pressure Range: – From page 9

Typical Example:	1	2	3	4	5	6
	1082(*)S	6"	P K Monel	Back ¼ NPT	XAY	0/600 psi

### Table A – Case Selections

Case Type	Dial Size	Case Style	Case Material and Finish	Ring Material Style and Finish	Mounting an Connection Location
1082(*)S (standard)	4½" 6" 8½"	Solid Front	Aluminum Black epoxy	Hinged steel Black wrinkle finish	Stem – Lower or back Flush – Back <sup>(1)</sup>
1082(*)S XAZ (option)	4½"	Solid Front Black epoxy	Aluminum Black epoxy	Threaded aluminum	Stem – Lower or back
1082(*)S XAY (option)	4½" 6"	Solid Front	Aluminum Black epoxy	Threaded reinforced polypropylene Black	Stem – Lower or back Surface – Lower or back 4½", 6" (order 1278M Ring)
1082(*)S XTY (option)	4½"	Solid Front	Phenolic Turret Black	Threaded reinforced polypropylene Black	Stem Lower or back Surface – Lower or back Flush – Back (order 1278M Ring)
1082(*)S XQY (option)	6"	Solid Front	Polypropylene (fiberglass reinforced) Black	Bayonet lock type polypropylene Black	Stem – Lower or back Surface – Lower or back (specify XBF) Flush – Back (specify XBQ)
1084(*)	3"	Open Front <sup>(2)</sup>	Polished stainless steel	Bayonet cam lock polished stainless steel	Stem – Lower
1080(*)S	8½"	Solid Front	Aluminum Black epoxy with handle	Hinged steel Black wrinkle finish	Stem – Lower or back

(\*) Bourdon Tube designation

(1) Case supplied with studs for flush mounting

(2) 1084 optional cover – specify 302B198-01

### Table B – Bourdon Tube Selection

Ordering Code	Bourdon Tube Tip Material (all joints TIG welded except "A")	Socket Material	Tube Type	Range Selection	Available with Case		NPT Connection*
					Size	Type	
A	Grade A Phospor Bronze Tube – Brass Tip, Silver Brazed	Brass	C-Tube	Vac/400 psi	4½, 6, 8½	1082	¼
S	316 Stainless Steel	316 Stainless Steel	C-Tube	Vac/1000 psi	3	1084	¼
P	K Monel	Monel 400	C-Tube	Vac/1500 psi	8½	1080	¼
			Helical	2000/10,000	4½, 6, 8½	1082	

\*Optional connection ½ NPT. Type 1084 is only available with ¼ NPT connection.



## Standard psi Ranges

## Type 1082

Range	Minor Graduations					
	4½	6	8½			
0/15	0.05	0.05	0.02			
0/30	0.1	0.1	0.05			
0/60	0.2	0.2	0.1			
0/100	0.5	0.2	0.2			
0/150	0.5	0.5	0.2			
0/200	0.5	0.5	0.5			
0/300	1	1	0.5			
0/400	1	1	1			
0/600	2	2	1			
0/800	2	2	2			
0/1000	5	2	2			
0/1500	5	5	2			
0/2000	10	5	5			
0/3000	10	10	5			
0/5000	20	10	10			
0/10000	50	20	20			
<b>Vacuum</b>						
30~Hg/0	0.1	0.1	0.05			
<b>Compound</b>						
~Hg/psi	Vac.	Press.	Vac.	Press.	Vac.	Press.
30/0/15	0.2	0.1	0.2	0.1	0.1	0.05
30/0/30	0.5	0.2	0.2	0.1	0.2	0.1
30/0/60	0.5	0.2	0.5	0.2	0.5	0.2
30/0/100	1	0.5	0.5	0.5	0.5	0.2
30/0/150	1	0.5	1	0.5	0.5	0.5
30/0/200	2	1	1	0.5	1	0.5
30/0/300	2	1	2	1	1	0.5
30/0/400	5	2	2	1	2	1

## Type 1084

Range	Graduations					
	Figure Interval		Minor Graduation			
<b>Pressure (psi)</b>						
0/15	1		0.1			
0/30	2		0.2			
0/60	5		0.5			
0/100	10		1			
0/150	10		1			
0/200	20		2			
0/300	20		2			
0/400	50		2			
0/600	50		5			
0/1000	100		10			
<b>Vacuum</b>						
30~Hg/0	2		2			
<b>Compound</b>						
inches mercury	psi	in.	psi	in.	psi	
30	15	5	2	0.5	0.2	
30	30	10	5	1	0.5	
30	60	10	10	2	1	
30	100	30	20	2	1	
30	150	30	50	2	1	
30	300	30	50	2	1	

## Type 1080

Range	Figure and Tab Intervals		
<b>Pressure (psi)</b>			
0/15	1		
0/30	2.5		
0/60	5		
0/100	5		
0/150	10		
0/200	10		
0/300	25		
0/400	25		
0/600	50		
0/800	50		
0/1000	50		
0/1500	100		
0/2000	100		
0/3000	250		
0/5000	500		
0/10000	500		
<b>Vacuum</b>			
30~Hg/0	2.5~ Hg		
<b>Compound</b>			
inches mercury	inches psi	mercury	psi
30	15	5	3
30	30	5	5

Standard Metric Ranges<sup>(1)</sup>

## Types 1080 and 1082

Range		
kg/cm <sup>2</sup>	bar	kPa
<b>Pressure</b>		
0/1	0/1	0/100
0/1.6	0/1.6	0/160
0/2.5	0/2.5	0/250
0/4	0/4	0/400
0/6	0/6	0/600
0/10	0/10	0/1000
0/16	0/16	0/1600
0/25	0/25	0/2500
0/40	0/40	0/4000
0/60	0/60	0/6000
0/100	0/100	0/10000
0/160	0/160	0/16000
0/250	0/250	0/25000
0/400	0/400	0/40000
0/600	0/600	0/60000
<b>Vacuum</b>		
-1/0	-1/0	-100/0
<b>Compound</b>		
-1/0/1.5	-1/0/1.5	-100/0/150
-1 /0/3	-1 /0/3	-100/0/300
-1/0/5	-1/0/5	-100/0/500
-1/0/9	-1/0/9	-100/0/900

(1) All standard metric ranges are available with psi dual scales.

## Type 1084

kg/cm <sup>2</sup>	bar	kPa
<b>Pressure</b>		
0/1	0/1	0/100
0/2	0/2	0/200
0/3	0/3	0/300
0/4	0/4	0/400
0/7	0/7	0/700
0/11	0/11	0/1100
0/14	0/14	0/1400
0/20	0/20	0/2000
0/28	0/28	0/2800
0/40	0/40	0/4000
0/70	0/70	0/7000
<b>Vacuum</b>		
-1/0	-1/0	-100/0
<b>Compound</b>		
-1/0/1	-1/0/1	-100/0/100
-1/0/3	-1/0/3	-100/0/300
-1/0/6	-1/0/6	-100/0/600
-1/0/10	-1/0/10	-100/0/1000

# Dimensions

Ashcroft® Test Gauges

## Case Type 1082(\*)S Standard

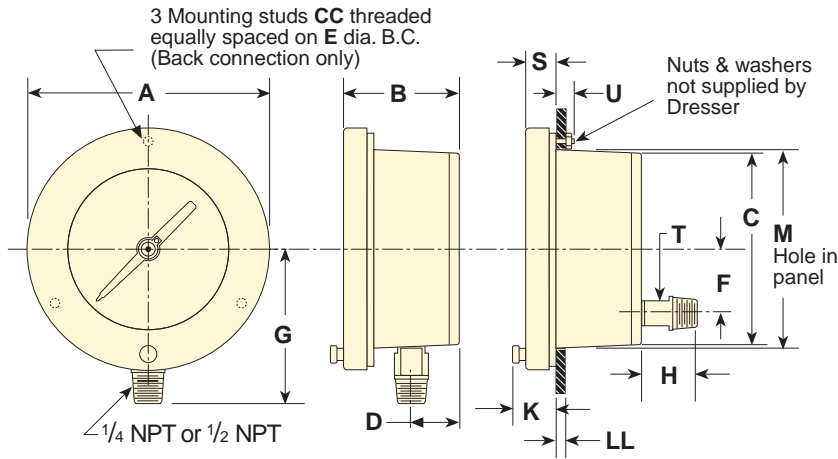

## Case Type 1084S

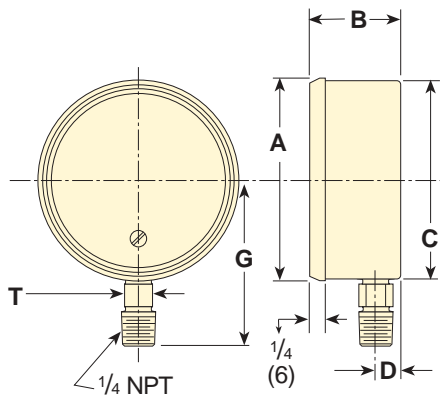

## Case Type 1080(\*)S

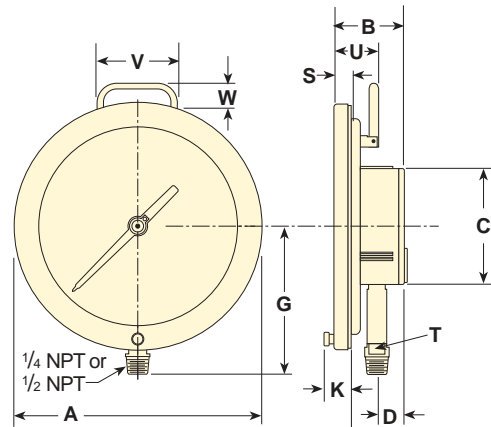

Model	Dial Size Inches	A	B	C	D	E	F	G	H	K	M	S	T	U	CC	LL	V	W
1082	4½	6 <sup>3</sup> / <sub>32</sub> (155)				5 <sup>5</sup> / <sub>8</sub> (137)		3 <sup>15</sup> / <sub>16</sub> (100)			4 <sup>7</sup> / <sub>8</sub> (124)				#10-24			
1082	6	7 <sup>7</sup> / <sub>16</sub> (192)	2 <sup>7</sup> / <sub>8</sub> (73)	4 <sup>3</sup> / <sub>4</sub> (121)	1 <sup>3</sup> / <sub>16</sub> (30)	7 (178)	1 <sup>5</sup> / <sub>8</sub> (41)	4 <sup>1</sup> / <sub>2</sub> (114)	1 <sup>3</sup> / <sub>8</sub> (35)	1 <sup>11</sup> / <sub>32</sub> (34)	6 <sup>1</sup> / <sub>2</sub> (165)	5 <sup>5</sup> / <sub>8</sub> (16)	5 <sup>5</sup> / <sub>8</sub> (16)	3 <sup>3</sup> / <sub>4</sub> (19)	1/4-20	1/8 to 1/2 (3) (13)	—	—
1082	8½	10 <sup>7</sup> / <sub>16</sub> (257)				9 <sup>5</sup> / <sub>8</sub> (244)		6 (152)			9 (229)				1/4-20			
1080	8½	10 <sup>7</sup> / <sub>16</sub> (257)	2 <sup>7</sup> / <sub>8</sub> (73)	4 <sup>3</sup> / <sub>4</sub> (121)	1 <sup>3</sup> / <sub>16</sub> (30)	—	—	6 (152)	—	1 <sup>11</sup> / <sub>32</sub> (34)	—	5 <sup>5</sup> / <sub>8</sub> (16)	5 <sup>5</sup> / <sub>8</sub> (16)	1 <sup>29</sup> / <sub>32</sub> (48)	—	—	3 <sup>3</sup> / <sub>4</sub> (83)	7 <sup>7</sup> / <sub>8</sub> (22)
1084	3	3 <sup>1</sup> / <sub>4</sub> (83)	1 <sup>15</sup> / <sub>32</sub> (37)	3 <sup>3</sup> / <sub>16</sub> (81)	1 <sup>13</sup> / <sub>32</sub> (10)	—	—	2 <sup>21</sup> / <sub>32</sub> (67)	—	—	—	—	7 <sup>7</sup> / <sub>16</sub> (11)	—	—	—	—	—

\*Millimeters shown in ( ).

### Case Type 1082(\*)S (XAZ)

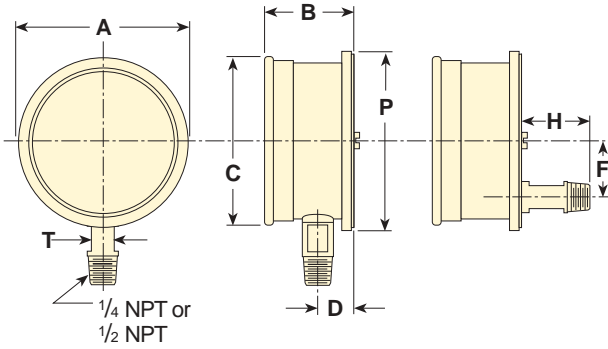

### Case Type 1082(\*)S (XAY)

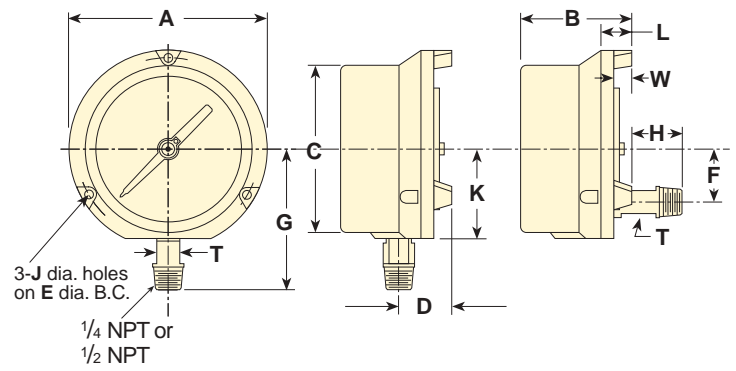

### Case Type 1082(\*)S (XTY)

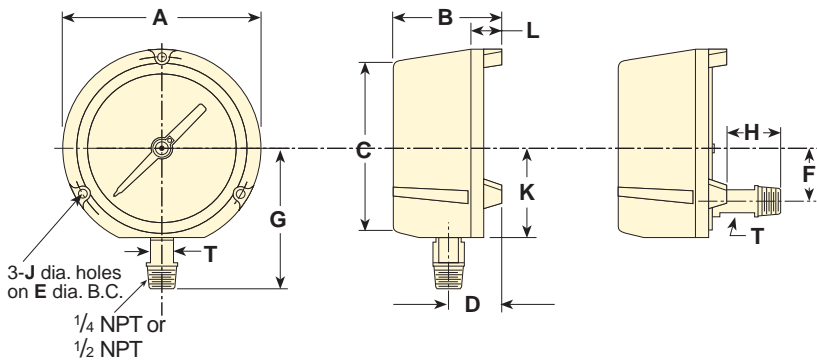

### Case Type 1082(\*)S (XQY)

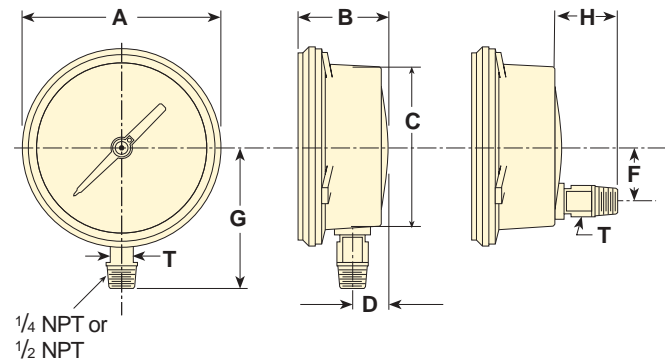

Model	Dial Size Inches	A	B	C	D	E	F	G	H		J	K	L	M	P	T
									Max.	Min.						
1082 XTY	4½	5 13/16 (148)	3 3/8 (86)	5 1/16 (129)	1 5/8 (41)	5 3/8 (137)	1 5/8 (41)	3 11/16 (94)	1 1/8 (29)	1 13/16 (21)	.218	2 5/8 (67)	1 5/16 (24)	—	—	5/8 (16)
1082 XAY	4½	5 13/16 (148)	3 7/16 (87)	4 7/8 (124)	1 5/8 (41)	5 3/8 (137)	1 5/8 (41)	3 11/16 (94)	7/8 (20)	—	.218	2 5/8 (67)	1 1/16 (27)	—	—	5/8 (16)
1082 XAY	6	7 5/8 (194)	3 1/2 (89)	6 3/8 (162)	1 5/8 (41)	7 (178)	1 5/8 (41)	4 7/16 (113)	7/8 (20)	—	.218	2 5/8 (67)	1 1/16 (27)	—	—	5/8 (16)
1082 XAZ	4½	5 1/16 (129)	2 37/64 (65)	5 1/16 (129)	1 5/16 (24)	—	1 5/8 (41)	3 11/16 (94)	1 13/16 (46)	1 1/16 (17)	—	—	—	—	5 13/16 (143)	5/8 (16)
1082 XQY	6	6 3/8 (162)	2 7/16 (67)	4 3/4 (121)	7/8 (22)	—	1 5/8 (41)	3 11/16 (94)	1 1/16 (40)	7/8 (22)	—	—	—	—	—	5/8 (16)

\*Millimeters shown in ( ).

## Instrument Division Sales and Customer Service Locations

### Domestic Headquarters

**Stratford, Connecticut**  
250 E. Main Street  
Stratford, CT 06614-5145  
Tel: (203) 378-8281  
Fax: (203) 385-0499

### Domestic Sales Offices

**Chicago, Illinois**  
400 W. Lake Street  
Suite 318  
Roselle, IL 60172-3573  
Tel: (630) 980-9030  
Fax: (630) 980-9440

**Hartford, Connecticut**  
1501 East Main Street  
Meriden, CT 06450-2860  
Tel: (203) 235-0450  
Fax: (203) 235-0593

**Houston, Texas**  
3838 North Sam Houston  
Parkway East  
Suite 120  
Houston, TX 77032  
Tel: (281) 590-1092  
Fax: (281) 590-7100

**Los Angeles, California**  
3931 MacArthur Blvd.  
Suite 202  
Newport Beach, CA 92660  
Tel: (949) 852-8948  
Fax: (949) 852-8971

**Mobile, Alabama**  
851 South Beltline Highway  
Suite 402, 4th Floor  
Mobile, AL 36606  
Tel: (334) 473-1692  
Fax: (334) 473-1782

### International Headquarters

**Stratford, Connecticut**  
250 E. Main Street  
Stratford, CT 06614-5145  
Tel: (203) 378-8281  
Fax: (203) 385-0357

### International Operations

**Brazil**  
Dresser Industria e  
Comercio Ltda.  
Divisao Manometros Willy  
Caixa Postal 212  
09510 Sao Caetano do Sul  
Sao Paulo, Brazil  
Tel: 55 -11-453-5477  
Fax: 55-11-453-8710

**Canada**  
Dresser Canada, Inc.  
2135 Meadowpine Blvd.  
Mississauga,  
Ontario L5N 6L5  
Canada  
Tel: 905-826-8411  
Fax: 905-826-9106

**China**  
Dresser Trading  
Room 2403, 24th Floor  
CITIC Bldg.  
19 Jianguo Menwai St.  
Beijing, P.R.C.  
Tel: 86-1-6500-3139  
Fax: 86-1-6512-0300

**France**  
Dresser Europe S.A.  
Division Instrumentation  
Immeuble Helsinki  
74, Rue d' Arceuil  
Silic 265, F-94578  
Rungis, Cedex  
France  
Tel: 33-01-49-79-22-59  
Fax: 33-01-46-86-25-24

**Germany**  
Dresser Europe S.A.  
Instrument Division  
Postfach 11 20  
Max-Planck-Str. 1  
D-52499 Baesweiler  
Germany  
Tel: 49-2401-8080  
Fax: 49-2401-7027

### Japan

Dresser Japan Ltd.  
Room 318, Shin Tokyo Building  
3-1 Marunouchi 3-Chome,  
Chiyoda-ku, Tokyo, Japan  
Tel: 813-3201-1501/1506  
Fax: 813-3213-6567/6673

### Korea

Dresser International S.A.  
Korea Office  
#2015 Kuk Dong Bldg.  
60-1, 3-KA, Choongmu-Ro,  
Chungku, Seoul, Korea 100-705  
Tel: 82-2-274-079-2/3  
Fax: 82-2-274-0794

### Mexico

Dresser Instrument Division  
Henry Ford No. 114,  
Esq. Foulton, Fracc  
Industrial San Nicolas  
54030 Tlalneplantla edo  
de Mexico 54030  
Tel: 525-310-7217  
Fax: 525-310-2608

### Saudi Arabia

Dresser Al Rushaid  
(DARVICO)  
P.O. Box 10145  
Jubail Industrial City  
Saudi Arabia 31961  
Tel: 966-3-341-0278  
Fax: 966-3-341-7624

### Singapore

Dresser Singapore Pte Ltd.  
Instrument Operations  
Block 1004 Toa Payoh North  
#07-15/17  
Singapore 318995  
Tel: 65-252-6602  
Fax: 65-252-6603

### United Kingdom

Dresser U.K. Ltd. Instrument Operation  
Rufford Court  
Hardwick Grange  
Warrington, Cheshire  
England WA1 4RF  
Tel: 44-1925-814545  
Fax: 44-1925-816378

### Venezuela

Manufacturas Petroleras  
Venezolanas S.A.  
Apartado Postal 617  
Maracaibo, Venezuela  
Tel: 58-61-579-762 or 070  
Fax: 58-61-579-461



A Halliburton Company

Visit our web site [www.dresser.com/instruments](http://www.dresser.com/instruments)

All specifications are subject to change without notice.  
All sales subject to standard terms and conditions.  
© Dresser Instrument Division, 3/99 20MCP 3P4/99